

THIS DRAWING IS UNPUBLISHED. RELEASED FOR PUBLICATION
 © COPYRIGHT BY TYCO ELECTRONICS CORPORATION. ALL RIGHTS RESERVED.

LOC	DIST	REVISIONS					
AD	00	P	LTR	DESCRIPTION	DATE	DWN	APVD
			B	REVISED PER ECN-0S12-0529-04	06FEB06	JDP	AMS

1. WIRE BARREL WILL ACCEPT 10 AWG WIRE.
 2. RECOMMENDED CRIMPING TOOL: DANIELS TOOL #M300-BT, POSITIONER PART NUMBER SP689, SETTING #3, STRIP LENGTH 8.13[.320].
- 3 0.00076 [.000030] MIN GOLD PLATE IN MATING AREA.
 TIN LEAD PLATE IN CRIMP AREA.

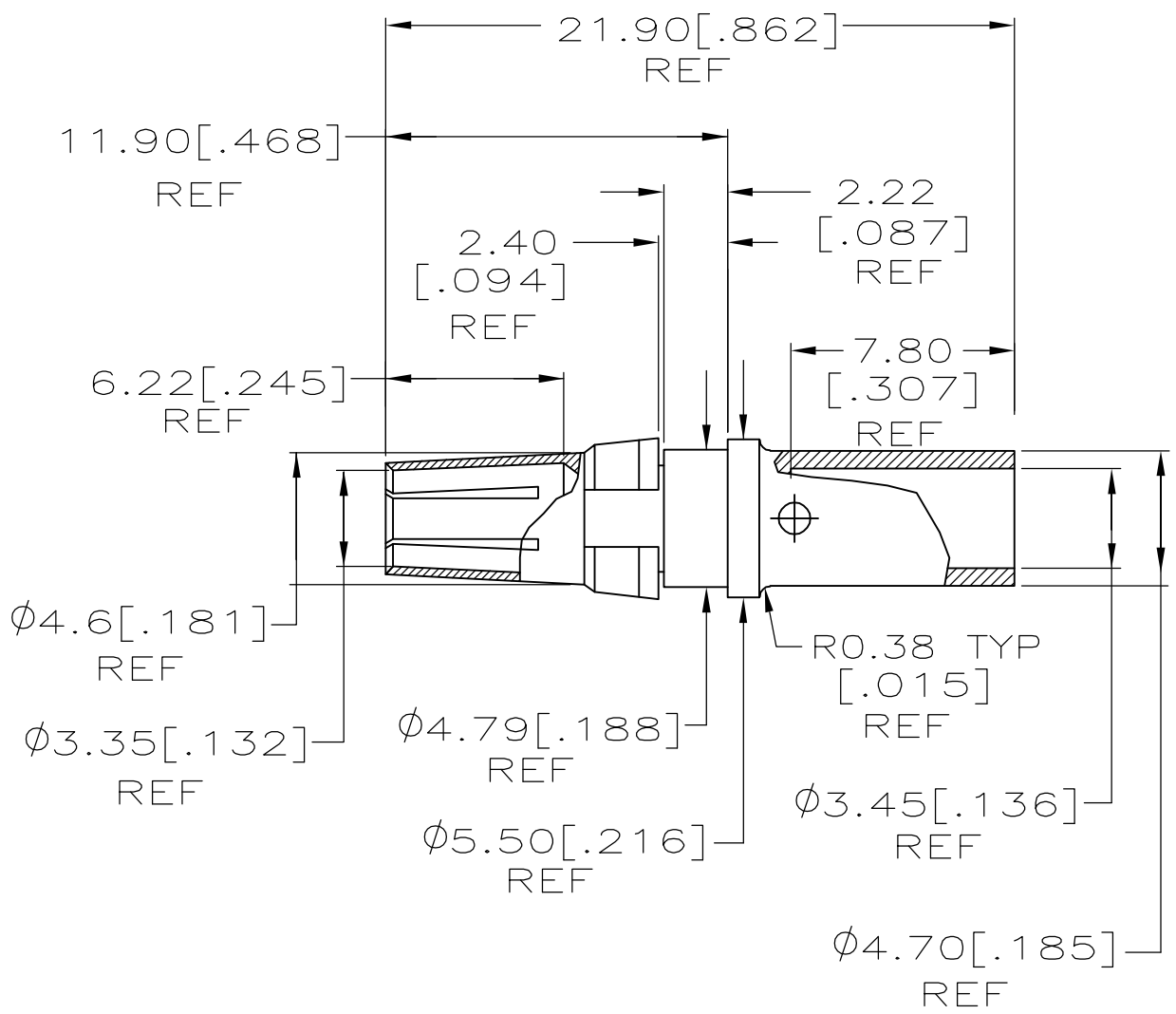

CONTACT; COPPER ALLOY	148357-1
RETAINING RING; COPPER ALLOY	
MATERIAL	PART NUMBER

THIS DRAWING IS A CONTROLLED DOCUMENT.		DWN	L. BRINER	19APR96	tyco Electronics	Tyco Electronics Corporation	
DIMENSIONS: mm [INCHES]		CHK	R. PATTERSON	19APR96		Harrisburg, PA 17105-3608	
TOLERANCES UNLESS OTHERWISE SPECIFIED:		APVD	R. PATTERSON	19APR96	NAME		
0 PLC ± -		PRODUCT SPEC		POWER CONTACT, FEMALE, F.M.L.B., CRIMP, AWG 10			
1 PLC ± -		APPLICATION SPEC		-			
2 PLC ± 0.13[.005]		SIZE	A3	CAGE CODE	00779	DRAWING NO	C-148357
3 PLC ± -		WEIGHT	-		RESTRICTED TO		
4 PLC ± -		CUSTOMER DRAWING					
ANGLES ± -		SCALE		4:1		SHEET 1 OF 1	
FINISH		3		REV		B	
MATERIAL SEE TABLE							